



baranfiltration.com

Continuous Sand Filter





baranfiltration.com

BARAN Continuous Sand Filter Advantages

- No Channeling
- Low head loss
- Always clean effluent
- No need for backwash
- No clogging filter media
- Low energy consumption
- No need automatic valves
- Always dirty water effluent
- No need wash water storage tanks
- No need wash water collecting tanks
- Low operation and maintenance costs
- Uniform media filter bed size: 1.2 - 2 mm
- No shock loads on the wash water treatment system
- Handles high suspended solids without need for pretreatment





baranfiltration.com

The principle of BARAN Continuous Sand Filter is based on the countercurrent flow principle.

The water to be treated flows through the inner and lower part of the distributor and gets clean as it flows upwards through the sand bed prior to discharge filtrate outlet at the top. The sand, which contains entrapped solids, is conveyed from tapered bottom section of the unit, by means of an air pump mechanism, to the sand washer located at the top.

Cleaning of the sand commences in the pump itself, in which impurities are separated from the sand grains by the turbulent mixing action. The contaminated sand spills from the pump outlet into the washer labyrinth, in which it is washed by a small countercurrent flow of clean water.

The separated solids are discharged through the wash water outlet, while the grains of clean sand, which are heavier, return to the sand bed.

As a result, the bed is in slow constant downward motion through the unit. Compressed air, which is used for the sand pump, is provided via the control panel. Thus, water purification and sand washing both take place continuously, enabling the filter to remain in service without interruption.





baranfiltration.com

Dimension Data

Type	Diameter (m)	Surface (m ²)	Capacity	Outlet Tss
BCSF 15-40	1/5	1/77	18	1-5 ppm
BCSF 19-40	2	3/14	31	
BCSF 24-55	2/5	4/91	49	

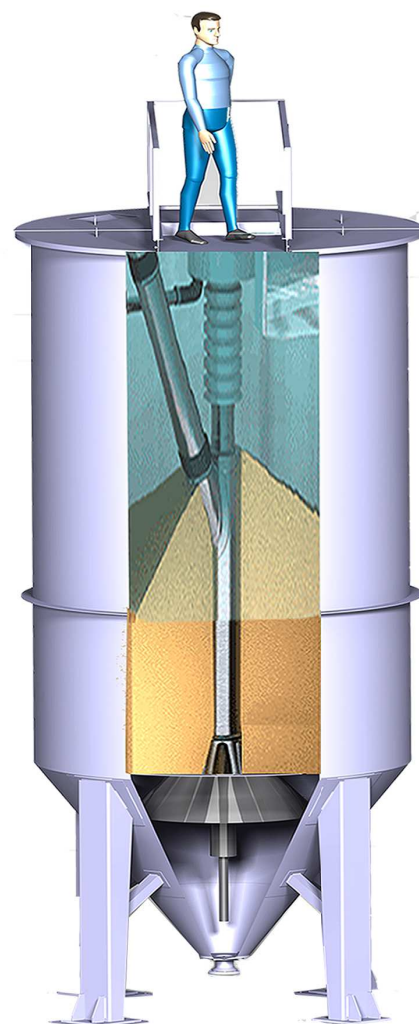
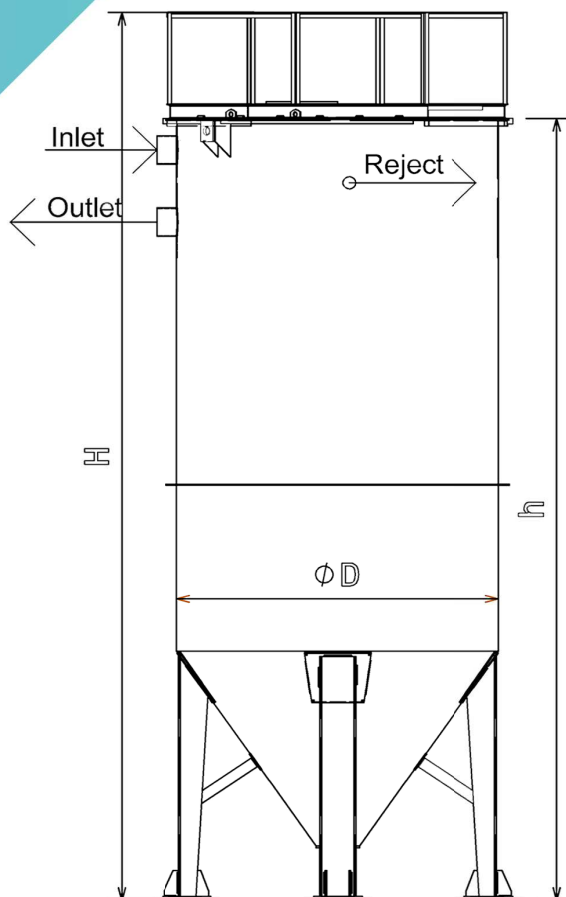

TAJHIZ SANAT BARAN



No. 7 - 3rd Narges Ave. - Azadi Blvd
Shams Abad Industrial Park - Tehran/Iran



www.baran-eet.com



(+98) 21 56901064 , 74
(+98) 2156807805



(+98) 21 43859477



info@baran-eet.com